

Physics 151 Class Exercise: Statics and Traction

1. The pulley arrangement shown below applies traction to a hapless skier's leg. A 25.0 kg mass acted on by gravity produces the tension in the rope that applies the traction. If the angles are as shown, what is the horizontal force applied to the leg? (Assume the pulleys are frictionless).

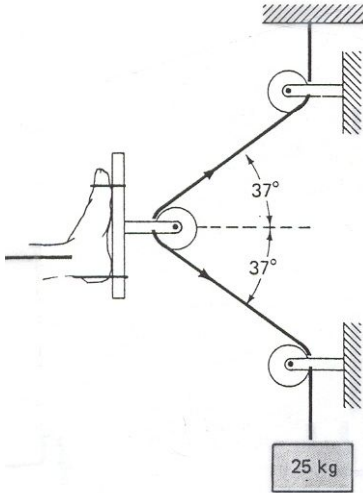

2. Calculate the vertical traction force exerted on the neck of the woman below. The hanging weight has a mass of 3.0 kg. (Assume that the free pulley cannot move horizontally.)

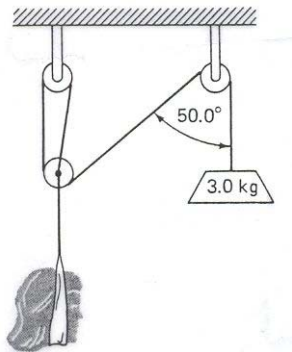

3. The figure below shows a device often used to provide support and traction for an injured leg. Determine the tension in the rope and the traction force (tension) on the leg.

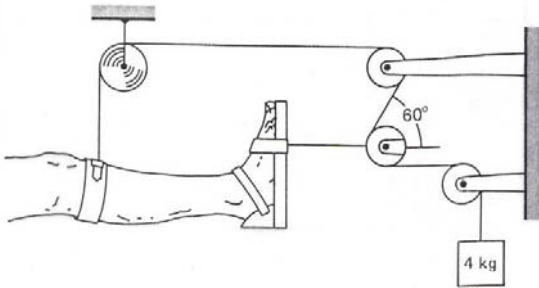

4. The Russell traction apparatus is used for fracture of a femur. The system is shown below. The mass of the leg is 4 kg and the tension required is 60 N. Find the values of masses m_1 and m_2 .

